

GSCCA-60 Spring Loaded Steel Draw Latch

Features

- Spring loaded design ideal for doors and covers that require dust or drip proofing

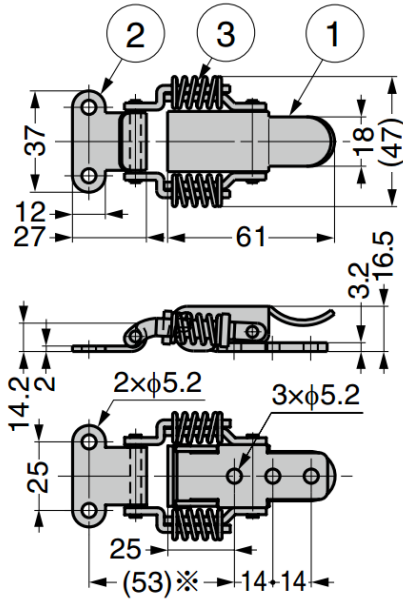

Clamping Margin mm	Clamping Force N	Clamping Force kgf
1	60	6.1
2	80	8.2
3	100	10.2

No.	Part Name	Material	Finish
①	Body	Steel (SPHC)	Clear Zinc Chromate (Trivalent)
②	Counter Plate		
③	Spring	Steel (SW)	-

Part No.	Load Capacity	
GSCCA-60	330 N	34 kg

※In case of clamping margin "0 mm".

GSCCA-40 Spring Loaded Steel Draw Latch

Features

- Spring loaded design ideal for doors and covers that require dust or drip proofing

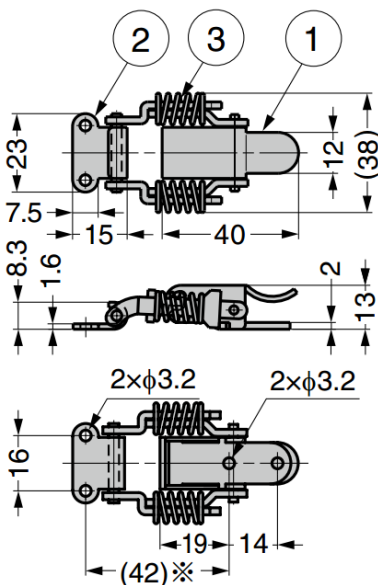

Clamping Margin mm	Clamping Force N	Clamping Force kgf
1	80	8.2
2	97.5	9.9
3	115	11.7

No.	Part Name	Material	Finish
①	Body	Steel (SPHC)	Clear Zinc Chromate (Trivalent)
②	Counter Plate		
③	Spring	Steel (SW)	-

Part No.	Load Capacity	
GSCCA-40	200 N	20 kg

※In case of clamping margin "0 mm".